

## ExpertArc ST-2200

### Simple. Stable. Ready to Weld

The ExpertArc ST-2200 gives manufacturers a dependable way to automate welding for the largest and heaviest parts. With a stationary worktable and overhead-mounted robot, it provides a stable platform for large fixtured weldments while maintaining clear access to the work area.

Built for repeatability and uptime, the ST-2200 delivers consistent weld quality in high-capacity fabrication. It's simple to run, ready to go, and built to make automation worth it.

**Welding automation is worth doing right.**

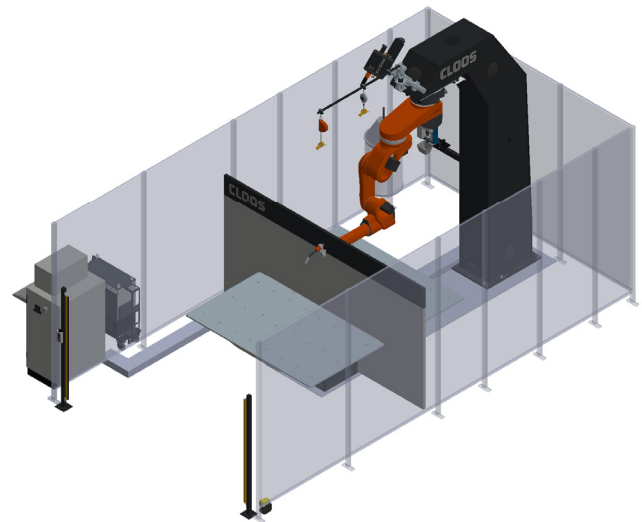

### SMART FEATURES. PROVEN BENEFITS.

> **Compact footprint**

Fits into tight shop floors and smaller production cells.

> **Simple to run**

Your team doesn't need to be robot programmers. Operators can run it with minimal training.

> **Fast to deploy**

Pre-configured, pre-tested, and ready to weld. You're up and running in days, not months.

> **Consistent, high-quality welds**

Clean, repeatable results every time. No guesswork. No surprises.

> **Less downtime**

Easier part loading, simpler programming, and fewer headaches in production.

> **Stable part positioning**

Stationary worktable keeps fixtures secure and parts consistently located through every weld cycle.

> **German engineered. American built.**

Precision and reliability, backed by decades of CLOOS welding expertise.

#### INDUSTRIES

General Industries & Job Shops

Construction & Heavy Equipment OEM's

Agricultural Equipment

Truck & Trailer Manufacturers

## PRODUCT SPECIFICATIONS

### SYSTEM INCLUDES

- > QRC-350e QIROX 7 Axis Robot
- > QRC 4.2 Robot Controller
- > StarT 406 Welding Power Source
- > Indexing Dual Station Positioner
- > Seam Tracking
- > Touch Sensing

### OPTIONS AVAILABLE

- > Upgraded Power Source
- > Aluminum Package with Push/ Pull Torch
- > iCSE Offline Laser Sensor
- > Fume Extraction Options
- > RoboPlan Offline Programming Software
- > C-Gate Cloud Based DMS
- > CLOOS Cares Service Program
- > HMI Operator Panel
- > Part Tooling

### MAXIMUM PART SIZE

Weight	2200 lbs	998 kg
Length	86 in	2,180 mm
Diameter	51 in	1,300 mm
Height	39 in	990 mm

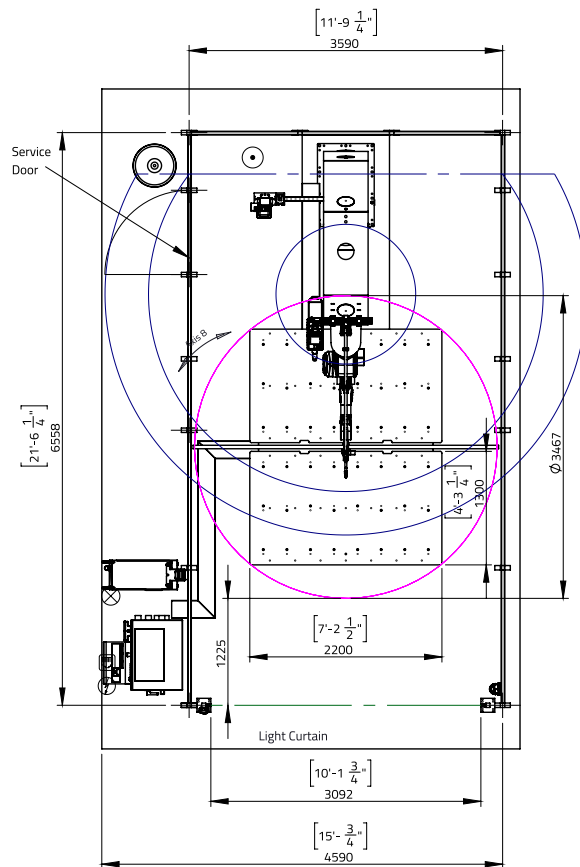

For additional details, please contact us at [sales@cloosna.com](mailto:sales@cloosna.com) or 847.923.9988.

SLS-10/13 ExpertArc ST-2200



CLOOS NORTH AMERICA  
[cloosna.com](http://cloosna.com) | 847.923.9988

**WORTH DOING RIGHT**

