

## ExpertArc HS-250

### Controlled Rotation. Smarter Welding.

The ExpertArc HS-250 is a headstock welding cell designed for smaller parts that benefit from controlled rotation. With 250 lb capacity per station and a single-axis positioner, it improves weld access without adding unnecessary complexity.

Pre-configured and easy to operate, the HS-250 gives job shops a practical first step into automation. It delivers consistent weld quality, better part positioning, and dependable performance, all in a compact footprint built for real production environments.

**Welding automation is worth doing right.**

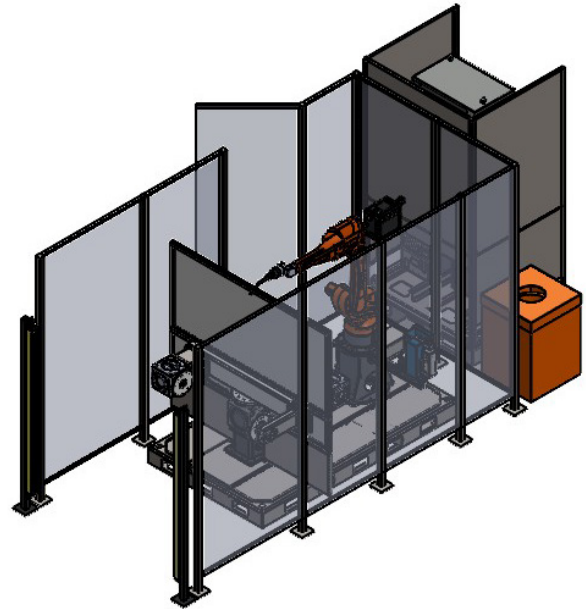

### SMART FEATURES. PROVEN BENEFITS.

> **Compact footprint**

Fits into tight shop floors and high-mix production cells.

> **Simple to run**

Your team doesn't need to be robot programmers. Operators can run it with minimal training.

> **Fast to deploy**

Pre-configured, pre-tested, and ready to weld. You're up and running in days, not months.

> **Controlled part rotation**

Servo-driven headstock positioner and a hollow wrist robot improve weld access and reduce manual repositioning.

> **Consistent, high-quality welds**

Clean, repeatable results every time. No guesswork. No surprises.

> **Less downtime**

Easier part loading, simpler programming, and fewer headaches in production.

> **German engineered. American built.**

Precision and reliability, backed by decades of CLOOS welding expertise.

#### INDUSTRIES

**General Industries & Job Shops**

Construction & Heavy Equipment OEM's

Agricultural Equipment

Truck & Trailer Manufacturers

## PRODUCT SPECIFICATIONS

### SYSTEM INCLUDES

- > QRH-280 QIROX Hollow Wrist Robot
- > QRC 4.2 Robot Controller
- > StarT 406 Welding Power Source
- > Indexing Dual Station Positioner
- > Seam Tracking
- > Touch Sensing

### OPTIONS AVAILABLE

- > Upgraded Power Source
- > Aluminum Package with Push/ Pull Torch
- > iCSE Offline Laser Sensor
- > Fume Extraction Options
- > RoboPlan Offline Programming Software
- > C-Gate Cloud Based DMS
- > CLOOS Cares Service Program
- > HMI Operator Panel
- > Part Tooling
- > Manax (Manual Jog)

### MAXIMUM PART SIZE

Weight	250 lbs	113 kg
Length	36 in	915 mm
Diameter	20 in	505 mm

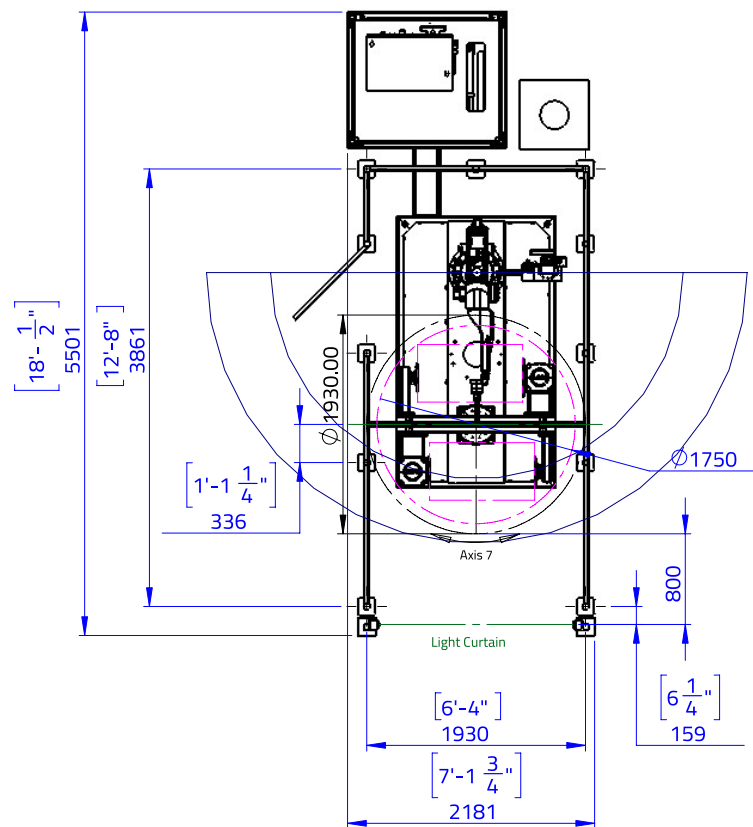

For additional details, please contact us at [sales@cloosna.com](mailto:sales@cloosna.com) or 847.923.9988.

SLS-1006 ExpertArc HS-250



CLOOS NORTH AMERICA  
[cloosna.com](http://cloosna.com) | 847.923.9988

**WORTH DOING RIGHT**

