

ExpertArc HS-2200

Controlled Rotation. Smarter Welding

The ExpertArc HS-2200 gives manufacturers an efficient way to weld the largest and heaviest weldments. With an overhead-mounted robot and dual work zones, it keeps operators loading while the system is welding—maximizing arc-on time without slowing production. This pre-engineered system is built for repeatability, uptime, and the demands of high-capacity fabrication.

Whether you're scaling production or automating large structural components, ExpertArc HS-2200 gives you the capacity and confidence to do it right.

Welding automation is worth doing right.

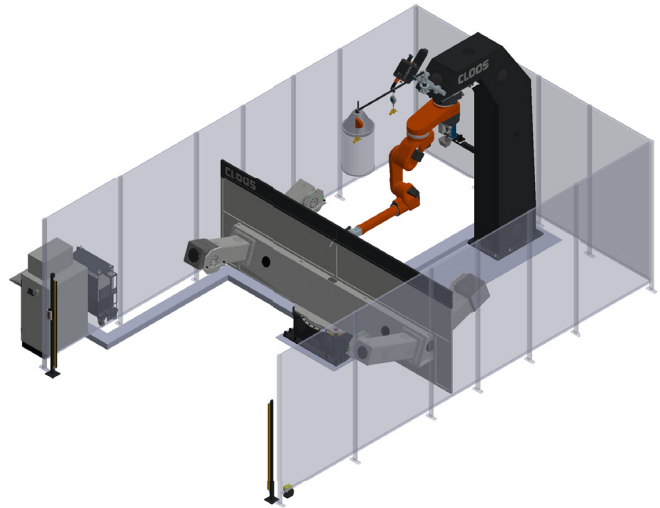

SMART FEATURES. PROVEN BENEFITS.

> **Compact footprint**

Fits into tight shop floors and high-mix production cells.

> **Simple to run**

Your team doesn't need to be robot programmers. Operators can run it with minimal training.

> **Fast to deploy**

Pre-configured, pre-tested, and ready to weld. You're up and running in days, not months.

> **Controlled part rotation**

Servo-driven headstock positioner and a 7-axis robot improve weld access and reduce manual repositioning.

> **Consistent, high-quality welds**

Clean, repeatable results every time. No guesswork. No surprises.

> **Less downtime**

Easier part loading, simpler programming, and fewer headaches in production.

> **German engineered. American built.**

Precision and reliability, backed by decades of CLOOS welding expertise.

INDUSTRIES

General Industries & Job Shops

Construction & Heavy Equipment OEM's

Agricultural Equipment

Truck & Trailer Manufacturers

PRODUCT SPECIFICATIONS

SYSTEM INCLUDES

- > QRC-410e QIROX 7 Axis Robot
- > QRC 4.2 Robot Controller
- > StarT 406 Welding Power Source
- > Indexing Dual Station Positioner
- > Seam Tracking
- > Touch Sensing

OPTIONS AVAILABLE

- > Upgraded Power Source
- > Aluminum Package with Push/ Pull Torch
- > iCSE Offline Laser Sensor
- > Fume Extraction Options
- > RoboPlan Offline Programming Software
- > C-Gate Cloud Based DMS
- > CLOOS Cares Service Program
- > HMI Operator Panel
- > Part Tooling
- > Manax (Manual Jog)

MAXIMUM PART SIZE

Weight	2,200 lbs	995 kg
Length	120 in	3,050 mm
Diameter	59 in	1,500 mm

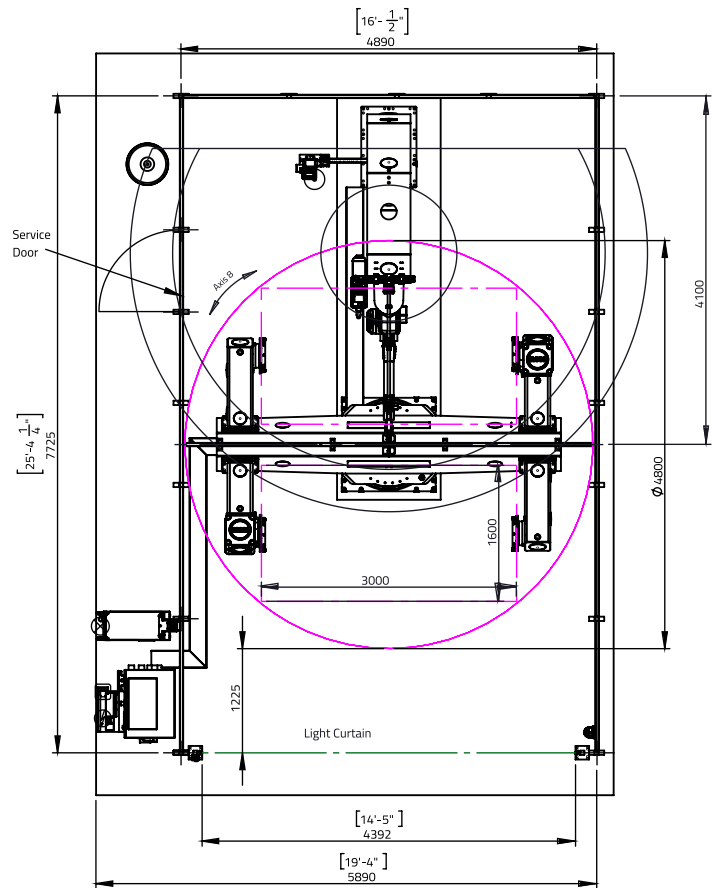

For additional details, please contact us at sales@cloosna.com or 847.923.9988.

SLS-1005 ExpertArc HS-2200



CLOOS NORTH AMERICA
cloosna.com | 847.923.9988

WORTH DOING RIGHT

