

ExpertArc Series 1100 - Dual Station

Dual-Axis Positioning. Maximum Flexibility.

The ExpertArc DA-1100 gives manufacturers a practical way to automate welding for medium-to-large weldments. With a dual-axis positioner and 1,100 lb capacity per station, it provides the tilt and rotation needed to reach multiple weld angles without constant repositioning.

Built for repeatability and uptime, the DA-1100 delivers consistent weld quality while keeping production moving. It's simple to run, ready to go, and built to make automation worth it.

Welding automation is worth doing right.

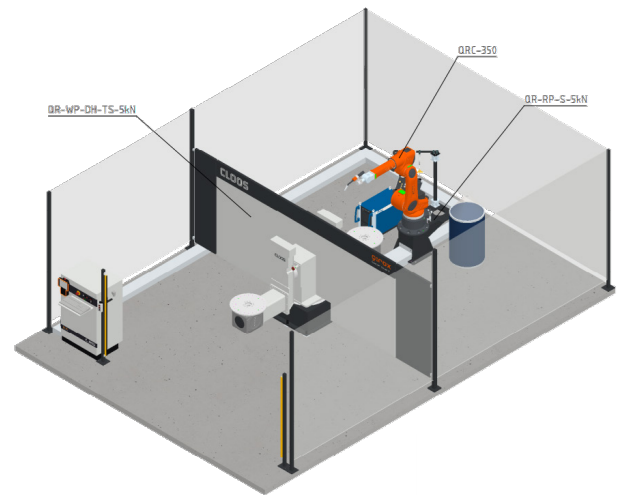

SMART FEATURES. PROVEN BENEFITS.

> Compact footprint

Fits into tight shop floors and high-mix production cells.

> Simple to run

Your team doesn't need to be robot programmers. Operators can run it with minimal training.

> Fast to deploy

Pre-configured, pre-tested, and ready to weld. You're up and running in days, not months.

> Dual-axis part positioning

Tilt and rotation improve weld access and reduces manual part repositioning.

> Consistent, high-quality welds

Clean, repeatable results every time. No guesswork. No surprises.

> Less downtime

Easier part loading, simpler programming, and fewer headaches in production.

> German engineered. American built.

Precision and reliability, backed by decades of CLOOS welding expertise.

INDUSTRIES

General Industries & Job Shops

Construction & Heavy Equipment OEM's

Agricultural Equipment

Truck & Trailer Manufacturers

PRODUCT SPECIFICATIONS

SYSTEM INCLUDES

- > QRC-350 QIROX Robot
- > QRC 4.2 Robot Controller
- > StarT 406 Welding Power Supply
- > Indexing Dual Station Positioner
- > Seam Tracking
- > Touch Sensing

OPTIONS AVAILABLE

- > Upgraded Power Supply
- > Aluminum Package with Push/ Pull Torch
- > iCSE Offline Laser Sensor
- > Fume Extraction Options
- > RoboPlan Offline Programming Software
- > C-Gate Cloud Based DMS
- > CLOOS Cares Service Program
- > HMI Operator Panel
- > Part Tooling
- > Manax (Manual Jog)

MAXIMUM PART SIZE		
Weight	1,100 lbs	500 kg
Length	47 in	1,195 mm
Diameter	49 in	1,245 mm

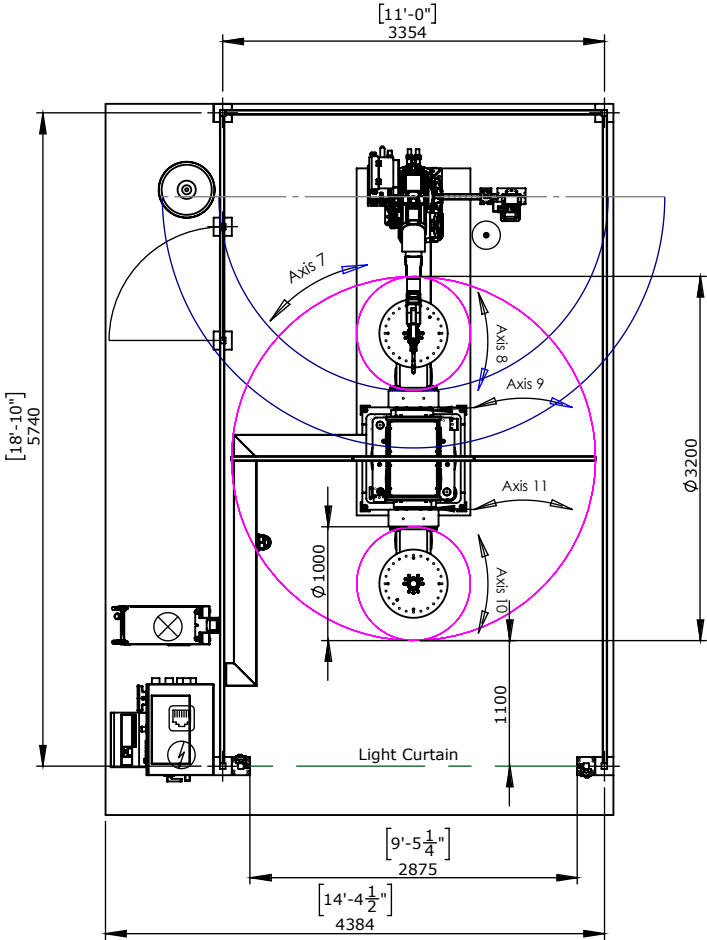

For additional details, please contact us at sales@cloosna.com or 847.923.9988.

SLS-1012 ExpertArc DA-1100



CLOOS NORTH AMERICA
cloosna.com | 847.923.9988

WORTH DOING RIGHT

