

ExpertArc Series 1100 - Dual Station

Controlled Rotation. Smarter Welding

The ExpertArc HS-1100 gives manufacturers a faster, easier way to weld larger, heavier parts. With a centrally mounted robot and dual work zones, it allows operators to load while the system welds, maximizing arc-on time without slowing production. This pre-engineered system is built for repeatability, uptime, and the demands of heavier weldments.

Whether you're scaling production or adding automation for larger components, ExpertArc HS-1100 gives you the capacity and confidence to do it right.

Welding automation is worth doing right.

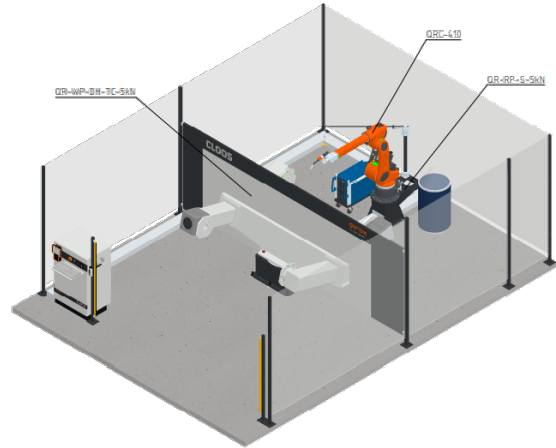

SMART FEATURES. PROVEN BENEFITS.

> Compact footprint

Fits into tight shop floors and high-mix production cells.

> Simple to run

Your team doesn't need to be robot programmers. Operators can run it with minimal training.

> Fast to deploy

Pre-configured, pre-tested, and ready to weld. You're up and running in days, not months.

> Controlled part rotation

Servo-driven headstock positioner improves weld access and reduces manual part repositioning.

> Consistent, high-quality welds

Clean, repeatable results every time. No guesswork. No surprises.

> Less downtime

Easier part loading, simpler programming, and fewer headaches in production.

> German engineered. American built.

Precision and reliability, backed by decades of CLOOS welding expertise.

INDUSTRIES

General Industries & Job Shops

Construction & Heavy Equipment OEM's

Agricultural Equipment

Truck & Trailer Manufacturers

PRODUCT SPECIFICATIONS

SYSTEM INCLUDES

- > QRC-410 QIROX Robot
- > QRC 4.2 Robot Controller
- > StarT 406 Welding Power Supply
- > Indexing Dual Station Positioner
- > Seam Tracking
- > Touch Sensing

OPTIONS AVAILABLE

- > Upgraded Power Supply
- > Aluminum Package with Push/ Pull Torch
- > iCSE Offline Laser Sensor
- > Fume Extraction Options
- > RoboPlan Offline Programming Software
- > C-Gate Cloud Based DMS
- > CLOOS Cares Service Program
- > HMI Operator Panel
- > Part Tooling
- > Manax (Manual Jog)

MAXIMUM PART SIZE		
Weight	1,100 lbs	500 kg
Length	78 in	1,980 mm
Diameter	47 in	1,195 mm

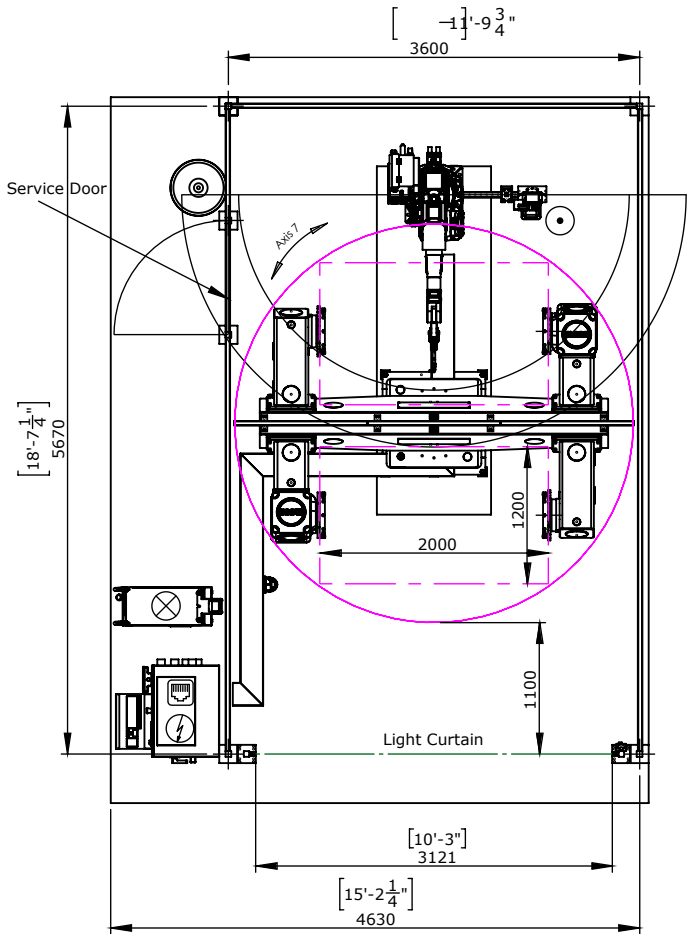

For additional details, please contact us at sales@cloosna.com or 847.923.9988.

SLS-1011 ExpertArc HS-1100



CLOOS NORTH AMERICA
cloosna.com | 847.923.9988

WORTH DOING RIGHT

