

ExpertArc Series 550 - Dual Station

Simple. Stable. Ready to Weld

The ExpertArc ST-550 is a stationary table welding cell built for shops that need reliable automation without added mechanical complexity. With a fixed worktable and 550 lb capacity, it's ideal for medium-sized parts that are already properly fixtured.

Powered by a welding-optimized robot with integrated cable routing, the ST-550 delivers clean torch access and consistent results shift after shift. Pre-configured and ready to run, it gives fabricators a straightforward way to increase throughput without overcomplicating production.

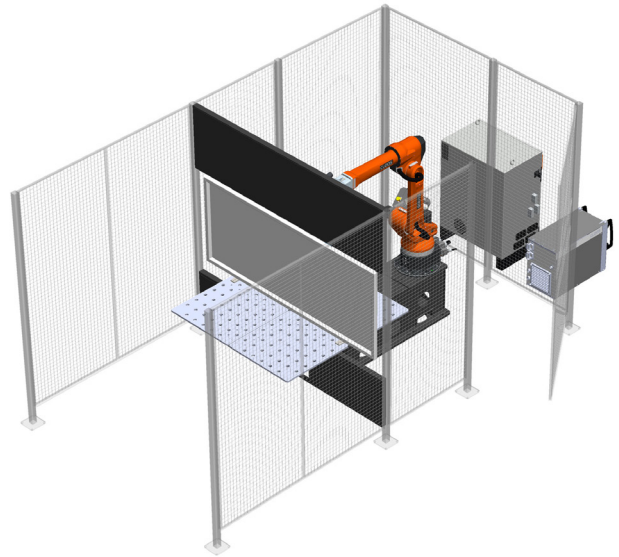

Welding automation is worth doing right.

SMART FEATURES. PROVEN BENEFITS.

> Compact footprint

Fits into tight shop floors and smaller production cells.

> Simple to run

Your team doesn't need to be robot programmers. Operators can run it with minimal training.

> Fast to deploy

Pre-configured, pre-tested, and ready to weld. You're up and running in days, not months.

> Consistent, high-quality welds

Clean, repeatable results every time. No guesswork. No surprises.

> Less downtime

Easier part loading, simpler programming, and fewer headaches in production.

> Stable part positioning

Stationary worktable and hollow wrist robot keep torch access clean and parts consistently located.

> German engineered. American built.

Precision and reliability, backed by decades of CLOOS welding expertise.

INDUSTRIES

General Industries & Job Shops

Construction & Heavy Equipment OEM's

Agricultural Equipment

Truck & Trailer Manufacturers

PRODUCT SPECIFICATIONS

SYSTEM INCLUDES

- > QRH-280 QIROX Hollow Wrist Robot
- > QRC 4.2 Robot Controller
- > StarT 406 Welding Power Supply
- > Indexing Dual Station Positioner
- > Seam Tracking
- > Touch Sensing

OPTIONS AVAILABLE

- > Upgraded Power Supply
- > Aluminum Package with Push/ Pull Torch
- > iCSE Offline Laser Sensor
- > Fume Extraction Options
- > RoboPlan Offline Programming Software
- > C-Gate Cloud Based DMS
- > CLOOS Cares Service Program
- > HMI Operator Panel
- > Part Tooling

MAXIMUM PART SIZE		
Weight	550 lbs	250 kg
Length	59 in	1,500 mm
Diameter	29 in	735 mm
Height	31 in	785 mm

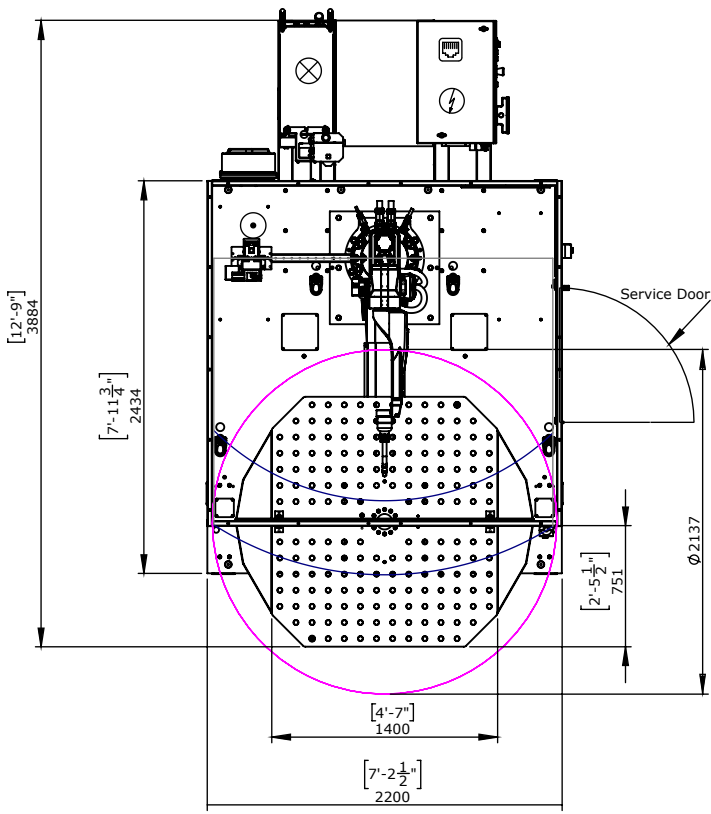

For additional details, please contact us at sales@cloosna.com or 847.923.9988.

SLS-1003 ExpertArc ST-550

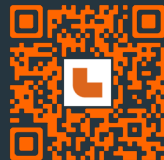

CLOOS NORTH AMERICA
cloosna.com | 847.923.9988

WORTH DOING RIGHT

